

GLUTÄCK®

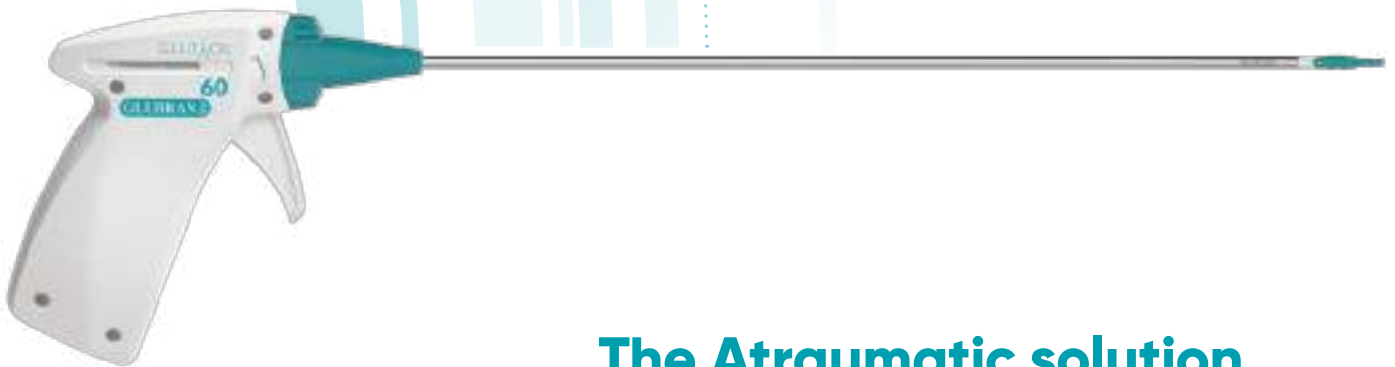

**The Atraumatic solution
for abdominal wall surgery**

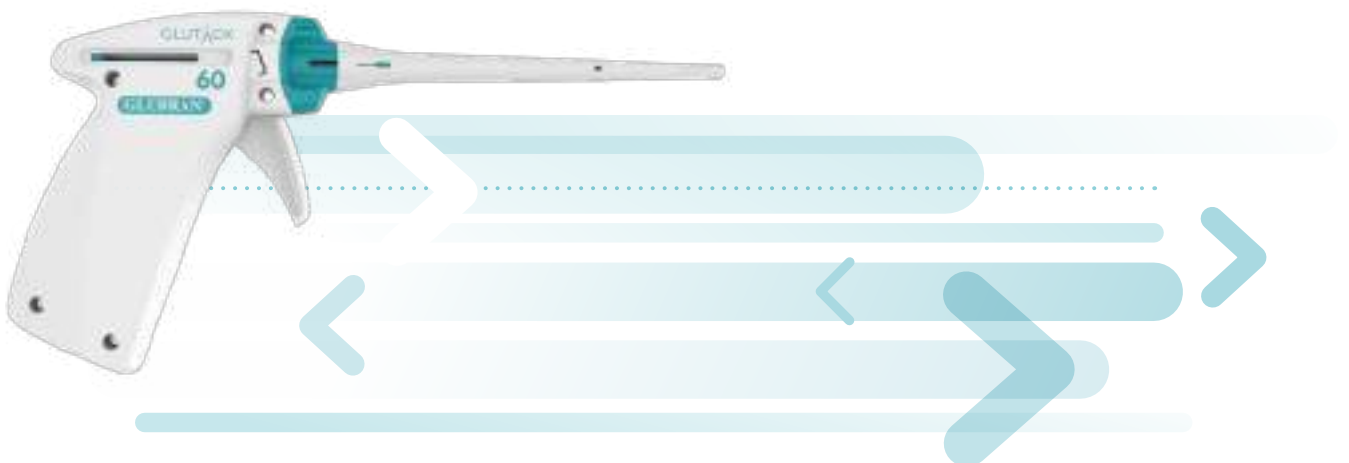

for **GLUBRAN²**



GEM SOLUTION
COMES FROM
EVOLUTION.



**Glutack®
your mesh
gently.**

GLUTACK®

A total evolution.

Designed with years of inherited experience of **Glubran®2** in atraumatic mesh fixation¹⁻²⁹.

Glutack® and Glutack® Short are user-friendly devices for the atraumatic fastening of hernia mesh. Providing precise and consistent delivery of Glubran®2 (NBCA+MS) with every pull of the trigger²⁴, to minimize surgical complications and the potential pain associated with the use of tacks and staples. Improving surgical outcomes and reducing healthcare costs¹⁻³³.

➤ **One Glutack® is dispensed with every pull of the trigger**

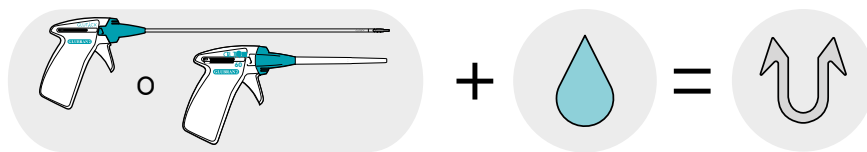

Glutack® + Glubran®2 = 1 high performance adhesive tack

➤ **No change in clinical practice: delivery method is similar to traditional mesh fixation devices**

➤ **Glubran®2 is effective in repairing hernias with less post-op pain, less complications, less recurrences and cost-effective is largely documented¹⁻³³**

➤ **Improves patient safety^{1,2,6,8} and surgeon confidence¹**

➤ **Keeps the mesh in place respecting the natural tissue ingrowth^{9,10}**

GLUTACK®

BUILDING THE



Atraumatic.

Versatile.

Multipurpose.

Glutack® + Glubran® 2 = 1 highly adhesive atraumatic fixation



GLUBRAN® 2

Synthetic biodegradable¹¹ cyanoacrylate adhesive modified by the addition of a monomer synthesized by the manufacturer GEM.

Polymerizes quickly in contact with live tissue and a wet environment⁸ creating a thin and elastic film¹² having high tensile strength which guarantees strong adhesion to the tissues^{10,13}.

Ready for use¹⁴⁻¹⁶ a high adhesive, sealant with haemostatic¹⁷ and bacteriostatic properties. Effective antiseptic barrier against the most diffused infective and pathogenic agents during the surgical intervention^{11,18,19}.

Class III medical device authorized since 1998 in open, laparoscopic surgery and endovascular uses²⁰.



> G-NB2-50



> G-NB2

GLUTÄCK®



**The gentle
power of
the drop.**



SAFE

- No clips or tacks: no tissue penetration, no nerve entrapment, no vessel damage^{6,21} (Fig.1)
- Less post-op pain^{6,33} (Fig.2)
- Reduces post-op complications^{1,2,6,23}
- Adhesive delivery controlled at all times – no drips²⁴
- Tip designed to avoid clogging and sticking²⁴
- Fixation even in high risk anatomical locations: around the Triangle of Doom, Triangle of Pain and close to the Diaphragm



STRONG

- High shear strength equivalent to the current fixing methods: more than 9 N/cm² Glutack[®]¹³ (Fig.3/5a)
- High peel force to remove the fixed mesh: 6N/cm² Glutack[®]²² (Fig.5b)
- No significant difference in the strength of parietal ingrowth between sutures²⁵, absorbable/permanent tacks and Glubran[®] 2¹⁰ (Fig.4)



FAST²⁴

- Very quick device preparation < 1 min
- Rapid, controlled Glutack[®] delivery
- Each precision Glutack[®] adheres the mesh to the tissue immediately



PRECISE²⁴

- Accurately controlled, repeatable Glutack[®] volume (0.0125 ml/drop)
- No product wastage



VERSATILE²⁴

- 2 different sizes: containing 30 or 60 Glutacks depending on mesh size / procedure requirement
- Articulating tip system to reach difficult areas (only for the laparoscopic model)



INTUITIVE²⁴

- Simple “point and shoot” design
- Handle geometry provides user comfort and multiple grip options
- Only a light input load on the trigger is required to drop the glue
- Audible and visual indicators confirm Glutack[®] delivery and number of Glutacks left
- The articulating tip of the laparoscopic model allows to deploy Glutacks perpendicular to the mesh and abdominal wall



FLEXIBLE²⁴

In laparoscopic procedures allows:

- Multiple angles of approach facilitated by articulating tip system
- Fasteners from any angle
- Elimination of contralateral ports



REALLY ATRAUMATIC

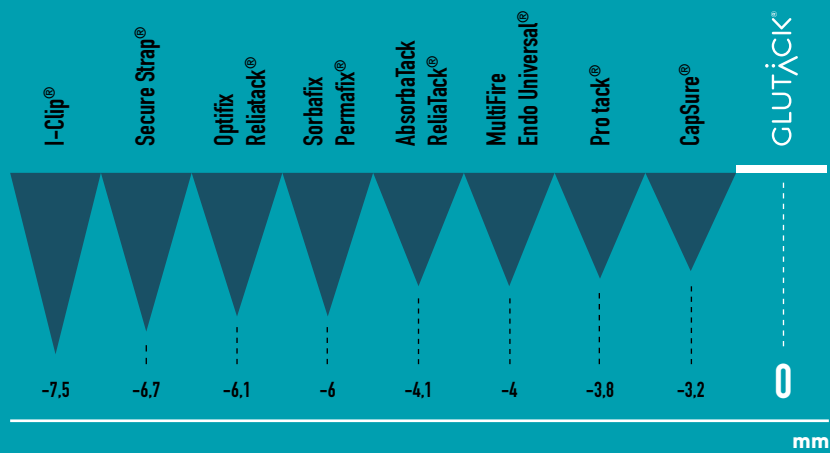

(Fig.1)

TISSUE PENETRATION (mm)^{21,30}

LESS PAIN

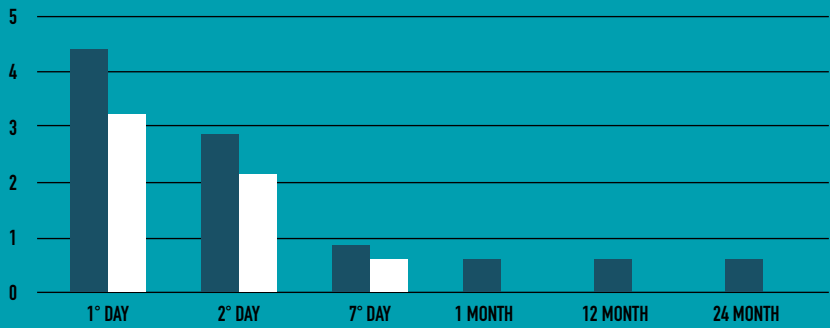

(Fig.2)

CLIPS
 GLUBRAN®

EVALUATION OF POSTOPERATIVE PAIN INTENSITY BY VAS SCALE⁶
 (modified by Burza A. et al. 2014).

ONE GLUTACK COMPARED TO COMPETITOR DEVICE

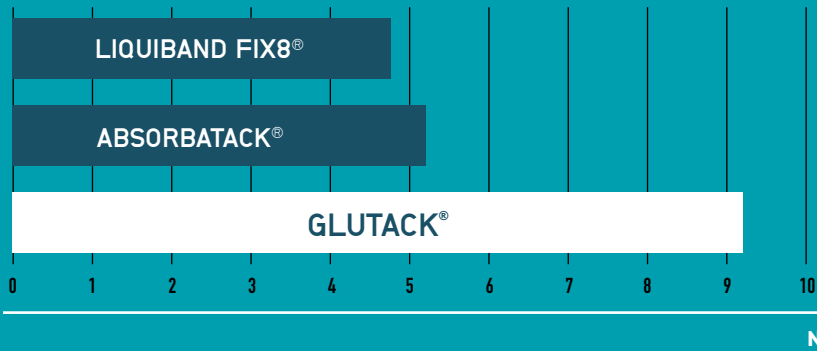

(Fig.3)

PRE-CLINICAL SHEAR STRENGTH EVALUATION IN AN IN VITRO MODEL FOR PP-DYNAMESH FIXATION¹³.

STRENGTH OF PARIETAL INGROWTH - 12 MONTHS

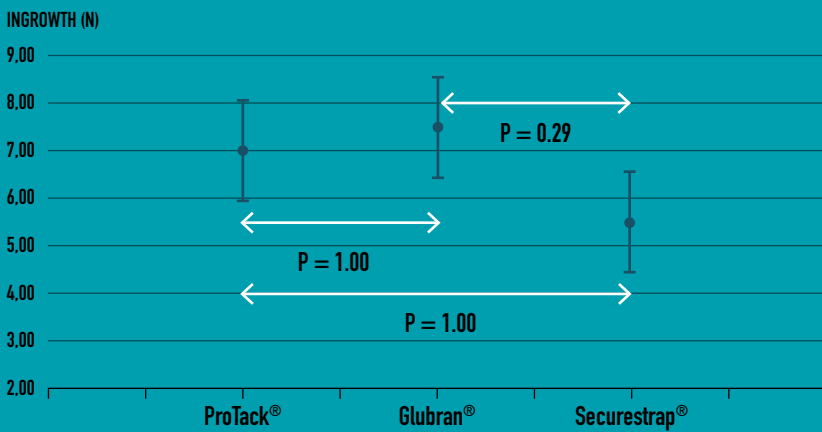

(Fig.4)

modified by Harsløf S. et al. 2017¹⁰.

GLUTACK® STRENGTH TEST^{13,22}



SHEAR 9N/CM²
(a)



PEELING 6N/CM²
(b)

(Fig.5a/5b)

GLUTACK®

Proven Efficacy.

Glutack® in action.

Laparoscopic



Repair of inguinal, hiatal, ventral and incisional hernias



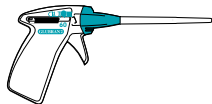

Laparotomy

Ventral hernia



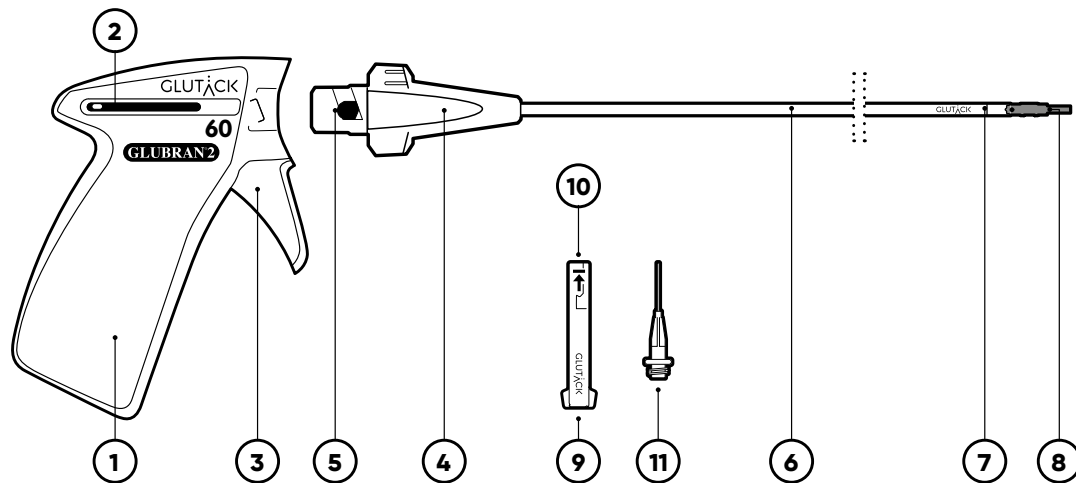

The sterile, latex free and single-use device consists of the following components:

- Handpiece (1) with label indicating the quantity of drops that can be dispensed; equipped with slider (2), which reveals the quantity of Glubran®2 dispensed during the procedure, and the trigger (3) connected to the gear that comprises the precise delivery system of the drops.
- Rigid catheter (external diameter of 5 mm) composed of:
 - connection base (4) with the symbol showing the mounting direction (5) and loading chamber for the loading cartridge (6);

- steel rod (7) ;
- articulated and adjustable end (8) equipped with a tip, designed to be anti-adhesive and clog resistant (9).
- Loading cartridge for the Glubran®2 (10).
- Transfer tip to be used to fill the cartridge with Glubran®2 (11).

Read always carefully the instructions for use (IFU) in the package leaflet.



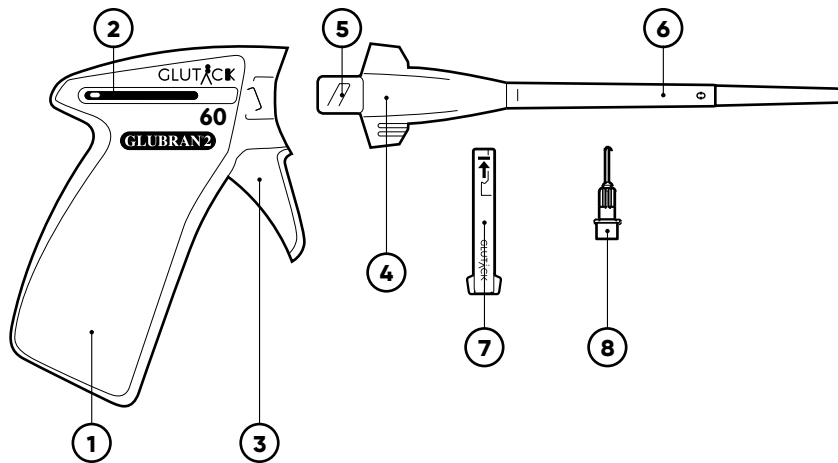

The sterile, latex-free, single-use device consists of the following components:

- Handpiece (1) with label stating the number of drops that can be dispensed; equipped with slider (2), which displays the amount of Glubran®2 dispensed during the procedure, and trigger (3) connected to the gear that forms the calibrated drop delivery system.
- Catheter consisting of:
 - coupling base (4) and chamber for housing the loading cartridge (5);
 - polyethylene shaft (6);
- Cartridge for Glubran®2 made of transparent plastic (7), pre-printed with symbols showing the

direction of insertion into the housing chamber and the loading level (8).

- Transfer tip to be used for loading the cartridge with Glubran®2 (8).

Read always carefully the instructions for use (IFU) in the package leaflet.



GLUTACK®

For every single need.

> GB-DS 30



Laparoscopic

> GB-DS 60



> GB-DS SH 30



Laparotomy

> GB-DS SH 60



Different variants containing **30** or **60** Glutacks depending on mesh size / procedure requirement.

Bibliography

- Kukleta JF, Freytag C, Weber M. Efficiency and safety of mesh fixation in laparoscopic inguinal hernia repair using n-butyl cyanoacrylate: long-term biocompatibility in over 1,300 mesh fixations. *Hernia*. 2012 Apr;16(2):153-62.
- Testini M, Lissidini G, Poli E, Gurrado A, Lardo D, Piccinni G. A single-surgeon randomized trial comparing sutures, N-butyl-2-cyanoacrylate and human fibrin glue for mesh fixation during primary inguinal hernia repair. *Can J Surg*. 2010 Jun;53(3):155-60.
- Grasso G., Florio G., Mari A., Del Papa M., Carni D.. Trattamento dell'ernia inguinale con procedura IPPM (intraperitoneal polyvinylidene fluoride polypropylene mesh): tecnica personale. *Osp. Ital Chir*. Luglio Settembre 2010.
- Paajanen H, Kössi J, Silvasti S, Hulmi T, Hakala T. Randomized clinical trial of tissue glue versus absorbable sutures for mesh fixation in local anaesthetic Lichtenstein hernia repair. *Br J Surg*. 2011 Sep;98(9):1245-51.
- Ladurner R, Drosse I, Seitz S, Plitz W, Barbaryka G, Siebeck M, Bürklein D, Kirchhoff C, Buhman S, Mutschler W, Schieker M, Mussack T. Tissue attachment strength and adhesion formation of intraabdominal fixed meshes with cyanoacrylate glues. *Eur J Med Res*. 2008 May;13(5): 185-91
- Burza A, Avantiori R, Curinga R, Santini E, Delle Site P, Stipa F. Comparison between two different mesh fixation methods in laparoscopic inguinal hernia repair: tacker vs. Synthetic cyanoacrylate glue. *Minerva Chir*. 2014 Dec;69(6):321-329.
- Eldabe Mikhail A, Palomo Luquero A, Reoyo Pascual JF, Seco Gil JL. Prosthetic material fixation in open inguinal hernioplasty: suture vs. synthetic glue. *Cir Esp*. 2012 Aug-Sep;90(7):446-52.
- Losi P, Burchielli S, Spiller D, Finotti V, Kull S, Briganti E, Soldani G. Cyanoacrylate surgical glue as an alternative to suture threads for mesh fixation in hernia repair. *J Surg Res*. 2010 Oct;163(2):e53-8.
- Harsløf S, Krum-Møller P, Sommer T, Zinther N, Wara P, Friis-Andersen H. Effect of fixation devices on postoperative pain after laparoscopic ventral hernia repair: a randomized clinical trial of permanent tacks, absorbable tacks, and synthetic glue. *Langenbecks Arch Surg*. 2018 Jun;403(4):529-537.
- Harsløf S, Zinther N, Harsløf T et al (2017) Polypropylene-mesh properties and type of anchoring do not influence strength of parietal ingrowth. *Langenbeck's Arch Surg* 402:1047-1054.
- Montanaro L, Arciola CR, Cenni E, Ciapetti G, Savioli F, Filippini F, Barsanti LA. Cytotoxicity, blood compatibility and antimicrobial activity of two cyanoacrylate glues for surgical use. *Biomaterials*. 2001 Jan;22(1):59-66.
- Haghpanah S, Vafafar A, Golzadeh MH, Ardeshiri R, Karimi M. Use of Glubran 2 and Glubran tissue skin adhesive in patients with hereditary bleeding disorders undergoing circumcision and dental extraction. *Ann Hematol*. 2011 Apr;90(4):463-8
- GEM internal test report 140415: Glutack Lap Shear strength evaluation done with different porous meshes.
- Garcia-Vallejo L, Couto-Gonzalez I, Concheiro-Coello P, Brea-Garcia B, Taboada-Suarez A. Cyanoacrylate surgical glue for mesh fixation in laparoscopic total extraperitoneal hernia repair. *Surg Laparosc Endosc Percutan Tech*. 2014 Jun; 24(3):240-3.
- Hosseini SM, Rasekhi AR, Zarenezhad M, Hedjazi A. Cyanoacrylate glue dressing for hypospadias surgery. *N Am J Med Sci*. 2012 Jul;4(7): 320-2.
- Ahmed E. Lasheen, Adel M. Tolba, Hany Mohamed, Hatem Mohammed, Nadia A. Smaeil. Laparoscopic Inguinal Hernia Repair with Closure of Hernial Defect and Central Mesh Fixation Using Glubran 2. *Surgical Science*, 2013, 4, 554-557.
- Kull S, Martinelli I, Briganti E, Losi P, Spiller D, Tonlorenzi S, Soldani G. Glubran 2 surgical glue: in vitro evaluation of adhesive and mechanical properties. *J Surg Res*. 2009 Nov;157(1):e15-21
- Karatepe O, Ozturk A, Koculu S, Cagatay A, Kamali G, Aksoy M. To what extent is cyanoacrylate useful to prevent early wound infections in hernia surgery? *Hernia*. 2008 Dec;12(6):603-7.
- Howell JM, Bresnahan KA, Stair TO, Dhindsa HS, Edwards BA (1995) Comparison of effects of suture and cyanoacrylate tissue adhesive on bacterial counts in contaminated lacerations. *Antimicrob Agents Chemother* 39:559-560
- Glubran 2 Technical Sheet - IFU Ver 11-2019
- Reynvoet E, Berrevoet F. Pros and cons of tacking in laparoscopic hernia repair. *Surg Technol Int*. 2014 Nov;25:136-40
- Villalobos R. et al. Laparoscopic ventral/incisional hernia repair with only glue mesh fixation using a new device: GLULAP experimental study. Poster presentation. Miami AHS-EHS 2018.
- Koch CA, Greenlee SM, Larson DR, Harrington JR, Farley DR. Randomized prospective study of totally extraperitoneal inguinal hernia repair: fixation versus no fixation of mesh. *JSLs*. 2006 Oct-Dec;10(4):457-60.
- On GEM data file.
- Dilege E, Devci U, Erbil Y, Dinçça A, Seven R, Ozarmagan S, Mercan S, Barbaros U. N-butyl cyanoacrylate versus conventional suturing for fixation of meshes in an incisional hernia model. *J Invest Surg*. 2010 Oct;23(5):262-6.
- Kukleta JF. Causes of recurrence in laparoscopic inguinal hernia repair. *J Minim Access Surg*. 2006 Sep;2(3):187-91.
- Agresta F, Baldazzi GA, Ciardo LF, Trentin G, Giuseppe S, Ferrante F, Bedin N. Lightweight partially absorbable monolament mesh (polypropylene/poliglecaprone 25) for TAPP inguinal hernia repair: initial experience. *Surg Laparosc Endosc Percutan Tech*. 2007 Apr;17(2):91-4.
- Garcia-Pastor P, Torregrosa A, Carvajal N, Garcá R, Alvarez E, Blasco R, B-Lledo J, Garcá Granero E. Nebulized cyanoacrylate for prostheses fixation in Rives-type eventroplasty. Usefulness of MRI-visible meshes for safety control. *P-1309- Hernia (2018) 22 (Suppl 1): S94-S189*.
- Panel P, Soffray F, Roussillon E, Devins C, Brouziyne M, Abramowicz S. Glue mesh fixation: Feasibility, tolerance and complication assessment. Results 24 months after laparoscopic sacrocolpopexy. *J Gynecol Obstet Hum Reprod*. 2017
- Data on official products catalogues.
- "A new device for mesh fixation with cyanoacrylate glue in laparoscopic TAPP repair for inguinal hernia" Fantacci R, Cobuccio L, Galatioto C.; Video-Poster presentation, 29° Congresso di Chirurgia dell'Apparato Digerente 28-29 Nov. 2018.
- Laparoscopic Repair of Ventral Hernia: A new non-traumatic method of Fixation. Nasti G. IV International Medical Film Festival Ryn Poland Ist Polish-French Joint Meeting of Hernia Clubs 22-24 Nov. 2018.
- Mitura K, Garnysz K, Wyrzykowska D, Michałek I. The change in groin pain perception after transabdominal preperitoneal inguinal hernia repair with glue fixation: a prospective trial of a single surgeon's experience. *Surg Endosc*. 2018 Oct;32(10):4284-4289.

SOLUTION COMES FROM EVOLUTION.



Via dei Campi 2 - PO Box 427 - 55049 Viareggio (LU) Italy
Tel. +39 0584 389784/391388 - Fax +39 0584 397904
www.gemitaly.it - info@gemitaly.it

